

Programme :- T.Y. B.Sc.

Subject : Physics

Semester : V

Course Code : PYC106 Section I- Analogue Electronics

Course Title : Analog and Digital Electronics

UNIT 1: Analog Electronics

**Module Name : IC-555 TIMER as MONOSTABLE
Multivibrator**

Shakeel alias AGA D. A.

Associate Professor

Govt. College, Sanquelim

Outline

IC-555 TIMER as MONOSTABLE
MULTIVIBRATOR

Learning outcomes

The Student will be able to :-

- 1) Draw the Block Diagram of IC-555 Timer as PULSE Generator and explain its working.

MONOSTABLE Multivibrator using 555 timer

A monostable multivibrator is also called as **ONE-SHOT** multivibrator .

Monostable multivibrator is a **PULSE Generator** circuit in which duration of the pulse is determined using **R-C** network. R-C network is connected externally to the 555 Timer. In a monostable circuit one state of the output is stable while the other is unstable. (quasi-stable)

Functional block diagram of 555 as monostable mode :-

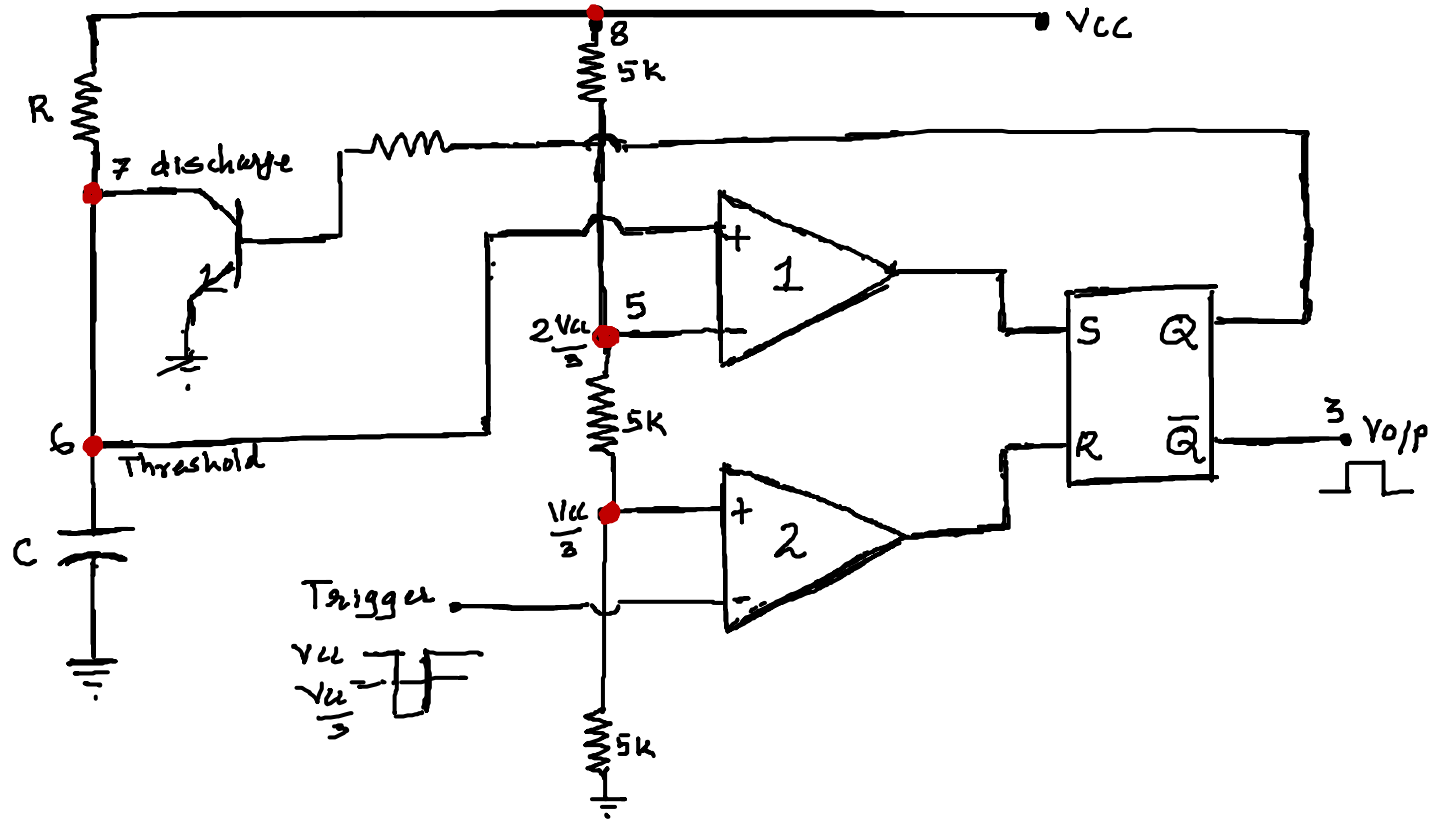

OPERATION :- Initially, when the output at pin no. 3 is low

i. e. $\bar{Q}=0$ means $Q=1$ therefore the transistor is in saturation position that means the voltage across the collector of the transistor is low and the capacitor C is shorted to ground.

(The capacitor discharges within no time)

When the negative pulse is applied at pin no.2 , the trigger input falls below $+V_{cc}/3$ then output of the comparator-2 goes

high and it resets the Flip-Flop. i.e. output at pin no. 3 is High. Since output of \bar{Q} is high then $Q=0$ and hence the transistor is in Cut-Off position. Voltage at the base of the transistor is low means voltage at the collector of the transistor is HIGH.

Therefore the capacitor "C" starts charging towards V_{cc} through resistance "R" with the time constant equal to "RC".

When the capacitor voltage becomes slightly more than $+2V_{cc}/3$, the output of the Comparator-1 goes HIGH, which

sets the FLIP-FLOP. (i.e. $Q=1$) The transistor goes to saturation, thereby discharging the capacitor "C" and the output of the Timer goes low. Thus the output returns back to stable state from unstable state.

The output of the **Monostable Multivibrator** remains low until a trigger pulse is again applied. Then the **cycle repeats**.

Trigger Input, Output Voltage and Capacitor Voltage waveforms are as shown.

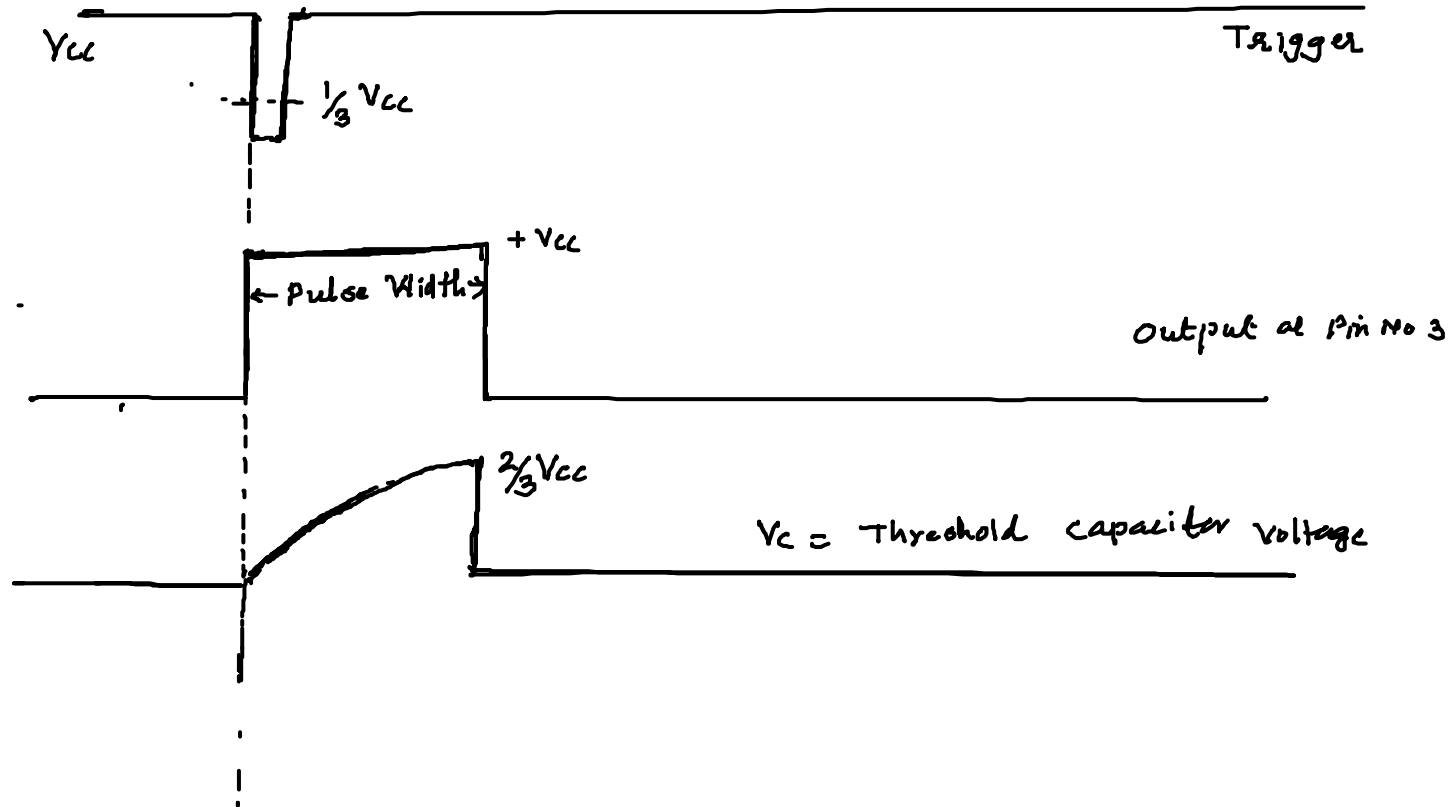

Expression for PULSE WIDTH of Monostable Multivibrator using -555

In this case the Capacitor charges through resistance R.

The basic equation for RC circuit is :-

$$V_c = V_i + (V_t - V_i) (1 - e^{-t/RC}) \text{ ----- (1)}$$

V_c = maximum voltage of the capacitor = $2V_{cc}/3$

V_i = Initial Voltage of the capacitor = 0

$V_t = \text{target voltage of the capacitor} = V_{cc}$

Therefore equation (1) becomes

$$2V_{cc}/3 = 0 + (V_{cc} - 0) (1 - e^{-t/RC}) \text{ -----(2)}$$

$$\text{i.e. } 2V_{cc}/3 = V_{cc} (1 - e^{-t/RC})$$

$$\text{i. e. } 2/3 = (1 - e^{-t/RC})$$

$$\text{i.e. } 2/3 - 1 = - e^{-t/RC}$$

$$\text{i.e.} \quad -1/3 = -e^{-t/RC}$$

$$\text{i. e.} \quad 1/3 = e^{-t/RC}$$

$$\text{therefore} \quad 3 = e^{t/RC}$$

$$\text{therefore} \quad \frac{t}{RC} = \log_e 3$$

$$\text{i.e.} \quad T = RC \log_e 3$$

i. e. $t = 1.1 RC$ PULSE WIDTH of MONOSTABLE MULTIVIBRATOR

Here C in farads R in Ohms & t in seconds.

Thus we can say that the voltage across the capacitor will reach $2V_{cc}/3$ in approximately 1.1 times time constant.

Therefore the PULSE WIDTH = $W = 1.1RC$

Schematic diagram of IC555 Monostable Multivibrator:-

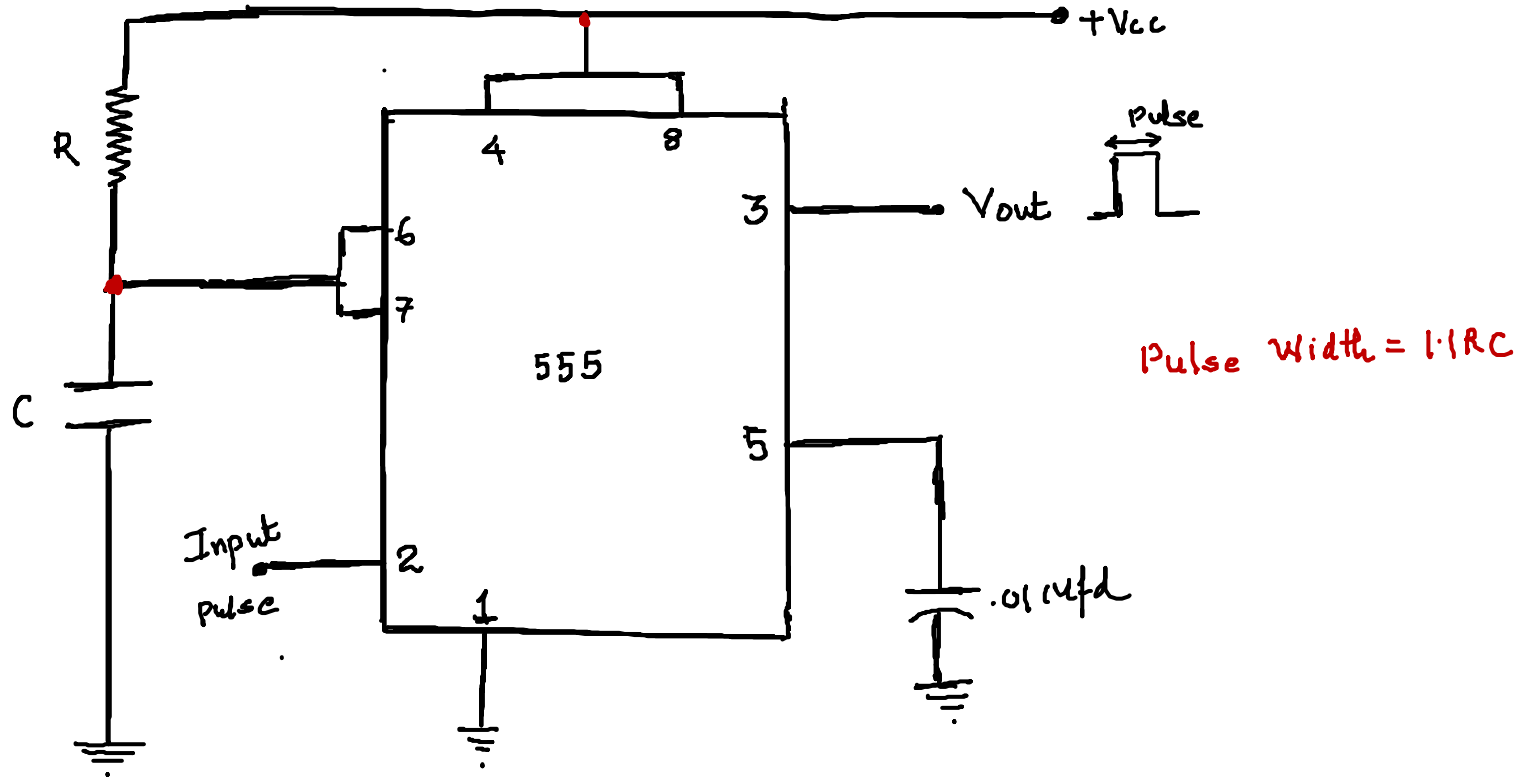

Here pin no. 1 is grounded. Trigger input is applied to pin no.2. In quiescent condition of output this input is kept at $+V_{cc}$.

To obtain transition of output from stable state to unstable state, a negative pulse of narrow width and amplitude of greater than $+2V_{cc}/3$ is applied to pin no.2.

Output is taken from pin no.3.

Pin no. 4 is usually connected to the supply to avoid accidental reset. Pin no. 5 is grounded through a 0.01 microfarad capacitor to avoid noise problem. Pin no 6 and pin no 7 are shorted. A resistor “R” is connected between pins 6 and 8. At pin no. 7 the discharge capacitor is connected. Pin no. 4 and 8 is connected to the Power Supply.

Applications of 555 in monostable mode :-

- 1) Frequency Divider
- 2) Pulse Width Modulator
- 3) Missing Pulse Detector
- 4) Linear Ramp Generator

Problem 1) Determine the Pulse Width of Monostable Multivibrator if $R = 10$ Kilo Ohm and $C = .01$ Microfarad. What will be the value of C if the pulse width is 0.1 milli-second?

Solution

$$\text{Pulse Width } T = 1.1RC$$

$$\begin{aligned} \therefore T &= 1.1 \times 10 \times K \times .01 \mu\text{fd} \\ &= 1.1 \times 10 \times 10^3 \times .01 \times 10^{-6} \\ &= 1.1 \times 10 \times .01 \times 10^{-3} \text{ Secs} \end{aligned}$$

$$T = 0.11 \text{ mSec}$$

To find C used in monostable
we have $T = 1.1RC$

$$\therefore C = \frac{T}{1.1R}$$

$$C = \frac{.1 \times 10^{-3}}{1.1 \times 10 \times 10^3} = \frac{0.1}{1.1 \times 10} \times 10^{-6}$$

$$\therefore C = 0.00909 \mu\text{fd.}$$

References and Acknowledgement

.

1) Electronic Principles A.P. Malvino TMH 5th edition 1996

2) Principles of Electronics by V.K. Mehta S. Chand &
Company 8th edition 2003

.

.

THANK YOU